

PITELUMEC

THE PRING-E 172 RING BIT CASING SYSTEM



CASING SIZE 219MM OD X 187MM ID DRILLING DIA. 235MM

PNEUMEC PRING-E 172 CASING SYSTEM

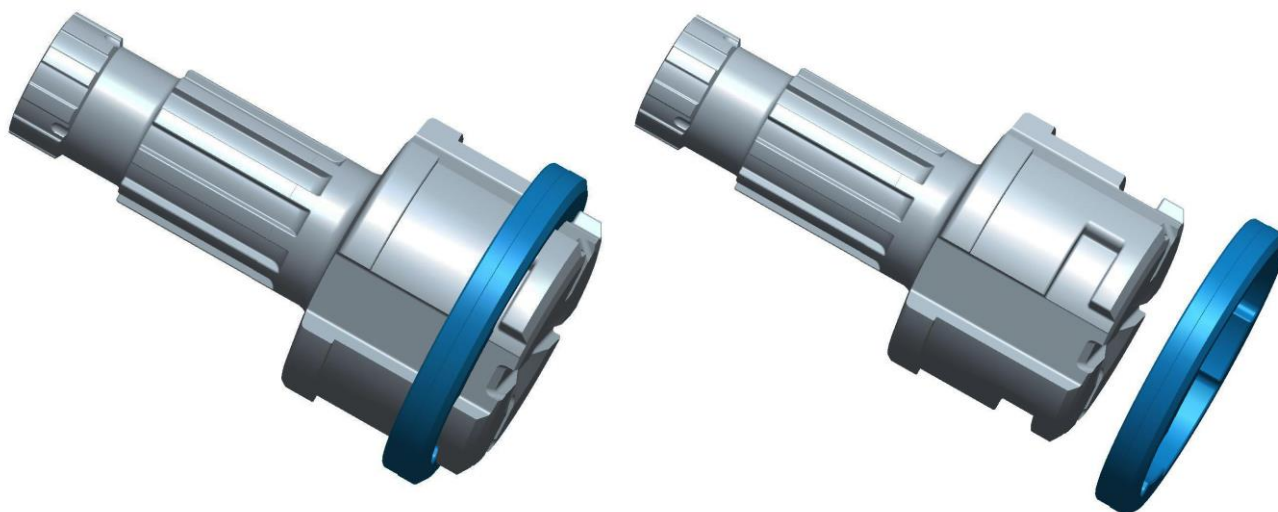

PRING-E 172 PARTS LIST

1.	DRIVER BIT DHD360 SHANK	UGD172360RE
2.	RING	URB172RE
3.	COMPLETE SYSTEM	UCS172360RE

PRING-E 172 SPECIFICATIONS

UPPER BODY DIAMETER	185MM	RING ID	146MM
RING OD	235MM	CASING SIZE	219MM OD X 187MM ID
SYSTEM LENGTH	524MM	SYSTEM WEIGHT	72KG

PRING-E 172 CASING SHOES

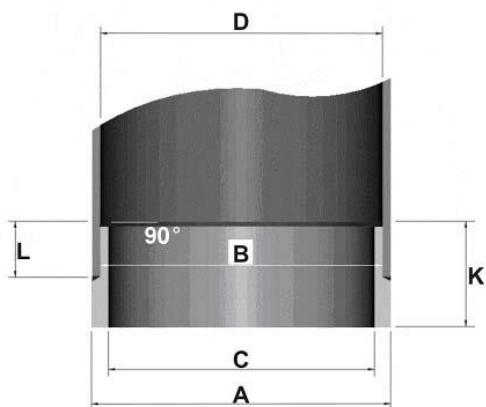

DIA. A	219MM
DIA. B	185MM
DIA. C	175MM
DIA. D	187MM
L	30MM
K	65MM



PNEUMEC COMPANY LIMITED

1st Floor, Tin On Sing Comm. Bldg., 41-43 Graham St. Central, H.K.

Tel : (852) 2172 9922

Fax : (852) 2172 9982

Website : www.pneumec.com

email : info@pneumec.com